

J. A. WILKIN.
FOOT OR HAND POWER.

No. 521,490.

Patented June 19, 1894.

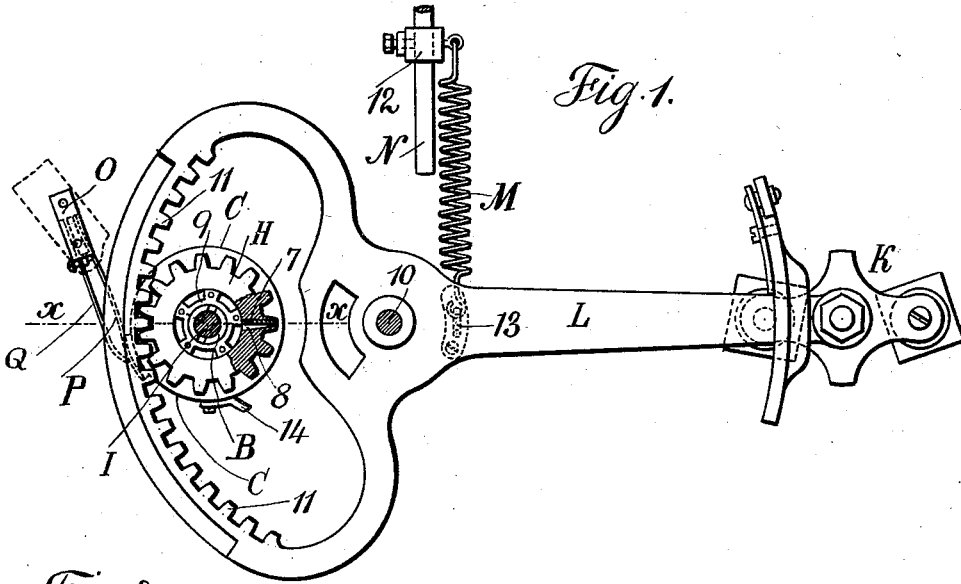

Fig. 1.

Fig. 3.

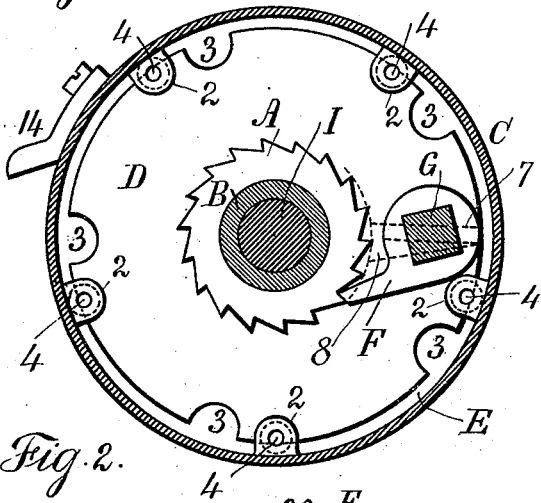
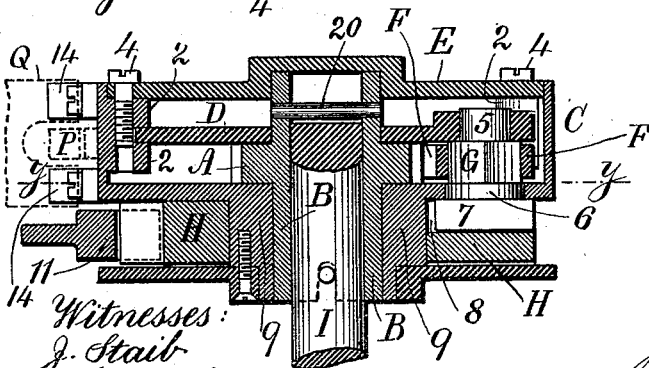
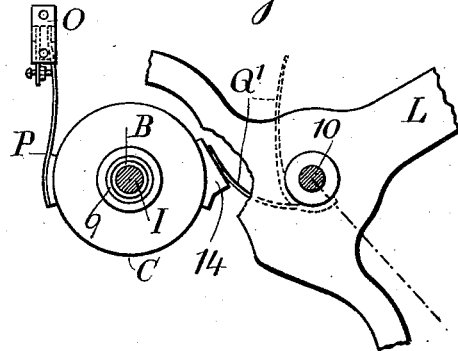

Fig. 2.

Fig. 4.



Witnesses:
J. Stair
Charles Smith

Inventor:
Joseph A. Wilkin
per Lemuel W. Ferrall
Atty.

J. A. WILKIN.
FOOT OR HAND POWER.

No. 521,490.

Patented June 19, 1894.

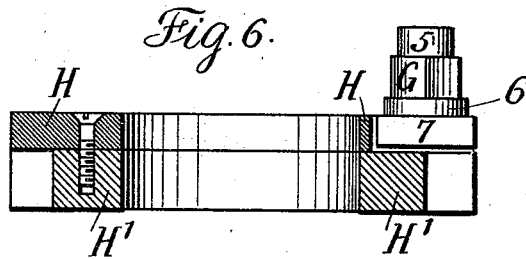
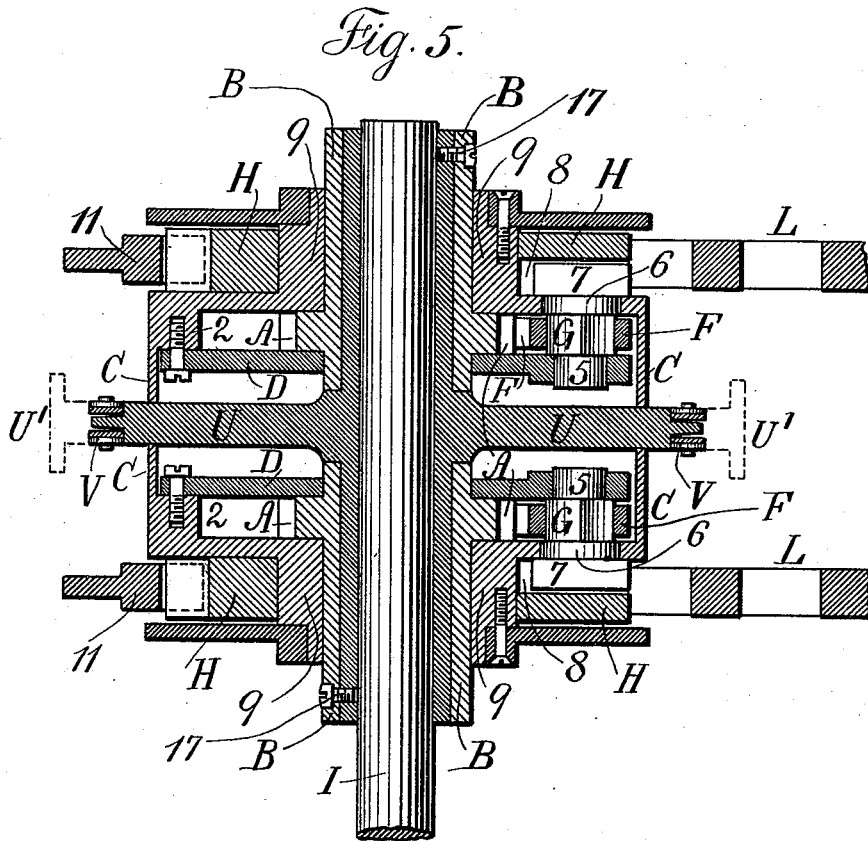

Witnesses:
J. Stair
Geo. T. Pinckney

Inventor:
Joseph A. Wilkin
per Lemuel W. Correll
Atty.

UNITED STATES PATENT OFFICE.

JOSEPH A. WILKIN, OF MATAMORAS, PENNSYLVANIA, ASSIGNOR TO HIMSELF,
AND JAMES J. MILLS, OF PORT JERVIS, NEW YORK.

FOOT OR HAND POWER.

SPECIFICATION forming part of Letters Patent No. 521,490, dated June 19, 1894.

Application filed May 22, 1893. Serial No. 475,007. (No model.)

To all whom it may concern:

Be it known that I, JOSEPH A. WILKIN, a citizen of the United States, residing at Matamoras, Pike county, in the State of Pennsylvania, have invented an Improvement in Foot or Hand Powers, of which the following is a specification.

This invention is especially intended for use with bicycles or tricycles in which the foot power is applied either to a crank shaft to rotate the same or to treadles that are raised by springs and depressed by the feet.

In this improvement the pawl that serves to give motion to the ratchet wheel or to receive motion from said ratchet wheel is raised automatically so that its end is out of contact with the teeth upon the ratchet wheel, thereby preventing wear upon the end of the pawl and also preventing noise. Devices have heretofore been constructed having this object in view, but the power that serves to lift the end of the pawl out of the ratchet teeth tends to bend or injure the pawl, while by my present improvement the pressure is equalized and the pawl itself is not strained by the power that acts in rotating the respective parts.

In the drawings, Figure 1 is an elevation with the cap plate removed and the pinion partially in section and representing a treadle and rack for giving motion to the pinion and sprocket or chain wheel. Fig. 2 is a transverse section in larger size at the line x x Fig. 1. Fig. 3 is a section at the line y y , Fig. 2, showing the pawl and ratchet wheel. Fig. 4 represents a modification of the stop. Fig. 5 is a sectional plan illustrating how the device may be used either with a sprocket wheel or pulley, and Fig. 6 represents the ring and the pinion as made in two pieces instead of in one piece.

The ratchet wheel A is rigidly connected to or formed with the tubular hub B, and this ratchet wheel is within the case C which is preferably circular, and the disk D within the case is supported by notched lugs 2 on the interior of the case C, and it is advantageous to notch the edges of the disk D, as at 3, and to place the disk D in its position within the case C, the lugs 2 passing through the notches 3, and when the disk is in its position the par-

tial rotation thereof causes the edge of the disk D to pass into the notches in the lugs 2, thereby holding the disk in its proper position, and a cap plate E is provided for the case C, such cap plate being secured by screws 4 passing into the notched lugs 2.

The pawl F is between the back of the case C and the disk D and the pawl is formed with a square or polygonal eye or opening in it for the reception of the pivot pin G which is made with a square fitting the eye or opening in the pawl and with a round end 5 passing into a hole in the disk D, and the circular outer portion 6 of the pivot pin fits a hole in the back of the case C, and there is outside of the case C and formed with the pivot pin a cross bar 7 which passes into a wedge-shaped notch 8 in the adjacent ring H which surrounds the hub 9 of the case C.

The construction and position of the parts are such that when pressure is applied by the ring H against the cross bar 7 of the pawl pivot, the point of the pawl is thrown down into the teeth of the ratchet wheel A, and when the pressure acts in the opposite direction the sides of the wedge-shaped notch 8 in the ring H pressing upon the cross bar 7 lift the point of the pawl out from the ratchet teeth, so that the ratchet wheel may be rotated without being in contact with the pawl; and it will be observed that the sides of the wedge-shaped notch 8 bear against either one side or the other of the cross bar 7 and take a uniform bearing upon the same; and that when the parts come to a bearing there is no further tendency to turn the pawl either in one direction or the other direction, and when the pawl is out of contact with the ratchet teeth the whole of the strain is taken by the cross bar and pivot pin directly upon the back of the case, and the strain also comes upon the pivot pin and the back of the case when the point of the pawl is in contact with the teeth of the ratchet, it being understood that when the point of the pawl sets against a ratchet tooth the side of the cross bar 7 sets against one of the faces of the wedge-shaped notch 8 in the ring H and the pawl is thrown either up or down immediately that there is a movement of the ring H upon the hub of the case C.

The before described parts are the principal ones in my improvement and they may be made use of for the ratchet power of a lathe or wherever available.

5 To illustrate the mode of its use I have shown the improvement in connection with the treadle for a velocipede, in which the treadle or foot-piece K is at the end of a lever L pivoted at 10 and having a segmental rack 11 engaging the teeth that surround the ring H, and there is a spring M to an adjustable clamp 12 upon the rod N, and this spring is connected by the eye 13 on the lever L and the spring M tends to raise the lever L when the pressure of the foot upon the treadle K is relieved; by this means the treadle is moved up and down and by the segmental rack 11 the toothed ring H is turned first in one direction and then in the other direction and the case C is also rotated or partially rotated first in one direction and then in the other direction, and when going in one direction the pawl F is pressed into contact with the teeth of the ratchet wheel A and turns the same, 25 rotating the tubular hub B of such ratchet wheel, and when the treadle is moving in the other direction and the ring H is rotated the reverse way, the point of the pawl F is raised out of contact, leaving the ratchet wheel free from the same. It is now to be understood that if the shaft I that passes through the tubular hub B is the shaft of one of the velocipede wheels and it is connected with the tubular hub B, the treadle on one side of the machine is depressed to give motion to the shaft of the wheel and propel the same while the treadle on the other side is being raised by the spring, and the reverse, so that a continuous rotary movement is set up by the alternate action of the treadles.

40 Where the present improvements are applied to rotate a sprocket wheel, the parts may be arranged as indicated in Fig. 5, in which the sprocket wheel U. is represented as permanently connected at 17. with the hubs B. of the ratchet wheels A. it being understood that the parts are employed in duplicate at the respective sides of the said sprocket wheel, and that the levers or treadles 50 L. and their racks 11. act upon the toothed rings or pinions H. and that one treadle or lever is to be depressed as the other rises, as usual, so as to maintain a continuous movement of the sprocket wheel. A portion of the chain that passes around the sprocket wheel is shown at V. and said chain may lead to a lathe, a bicycle wheel or any other article to be rotated.

60 If the improvement is applied to rotate a pulley or belt wheel, it is only necessary that the edge of the wheel U. be adapted to such a belt as indicated by the dotted lines U'. instead of having sprocket teeth around its edge.

65 In cases where a crank shaft passes through the tubular hub B and is provided with cranks upon the respective ends by which

such shaft and the tubular hub are rotated, the parts are to be placed in such a manner that the propelling power will act through the ring H and the pawl to rotate the case and also a sprocket wheel that is connected with the hub of the ratchet wheel, thereby giving motion through such ring H and connected parts to the chain passing around the sprocket wheel, and when the feet are taken off the pedals they may remain stationary, because the action of the parts will lift the pawl from contact with the ratchet teeth, and when pressure is reapplied to the cranks the pawl will be thrown into the teeth of the ratchet wheel.

When this invention is applied in the manner first described, it is important to apply to the periphery of the case C a detaining friction and a stop to prevent the momentum carrying the case beyond a complete revolution. With this object in view I provide a standard O upon any suitable portion of the frame of the velocipede and a spring P having a friction pad at the end thereof that bears upon the periphery of the case C, and there are two lugs 14 upon the periphery of the case that pass freely at opposite sides of the spring P, but the stop Q which is also supported by the standard O arrests the movement of the case by the lugs 14 coming in contact with such stop, thereby limiting the rotary movement of the case and applying a sufficient friction to such case to cause the end of the pawl to be thrown either into contact with the ratchet teeth or out of contact the moment a reverse movement is given to the motor devices.

It is to be understood that usually two sets of devices will be employed, each set being similar to that before described, so that one will be acted upon by one foot and the other by the other foot in converting the reciprocating motion into a rotary motion, as before described.

It is to be understood that a stop with a rubber cushion may be provided to limit the movement of the treadle lever and segmental rack as usual in machines of this character, and also that the relative size of the gear wheel or pinion formed by the teeth of the ring H to the segmental rack 11 may be varied to increase or lessen the leverage of the treadle in propelling the velocipede. The lugs 14 coming into contact with the inclined and forked end of the stop Q form a gradual stop or cushion that applies the proper pressure upon the ratchet case or box so as to hold the same with the necessary power while the power of the spring acting upon the treadle and segmental rack gives to the pinion ring H a partial rotary movement and lifts the pawl fully out of contact with the ratchet wheel previous to giving to the case a backward rotary movement, and the spring P with its friction pad continues to apply to the case a sufficient pressure to prevent the end of the pawl coming into contact with the teeth of the ratchet wheel through any looseness of

the parts, and the friction of this spring P is always sufficient to prevent the case being turned by the friction between the ratchet wheel and the interior of the box or case, so that there is no risk of the end of the pawl striking against the teeth of the ratchet under the different circumstances arising when the article is in use.

The pinion H' may be separate from and fastened to the side of the ring H instead of the teeth being in the edge of the ring, as shown in Fig. 6.

The number of pawls may be increased and the size of the pinion or the sprocket wheel may be varied according to the power or speed required.

In cases where the apparatus is placed directly upon the axle of the wheel to be rotated, there may be a cross pin 20 through the hub B and through a notch in the shaft or axle I, so that the case and ratchet wheel can be slipped off for cleaning the parts, in which instance the teeth of the segmental rack and the flange 21 will retain the parts in position and the case and its parts can be removed with the segmental rack after the nut on the pivot 10 has been taken off.

By placing the stops Q' on the hub of the lever L instead of being on the frame of the cycle, the stops will come into contact with the lugs 14 on the case only when the treadle lever is drawn fully up by its spring, and hence the case will be free to turn one or more times when the treadle levers are being operated, but the friction spring P will always apply to the case the necessary detaining force to cause the pawl to be thrown into or out of action.

I claim as my invention—

1. The combination with the ratchet wheel and its axis, of two parts movable around such axis, one of which parts has a wedge-shaped slot, a pawl having a pivot supported by the other part, and a bar across the axis of the pawl entering the wedge-shaped slot, whereby one side of the wedge-shaped slot when pressed against the cross bar causes the pawl to separate from the ratchet and the other side of the slot when pressed against the cross bar causes the pawl to engage the ratchet wheel and give motion to the same, the pressure coming directly on the pivot of the pawl, substantially as specified.

2. The combination with the ratchet wheel and pawl, of a case having notched lugs upon the interior thereof, a disk fitting into the case and having notches and being supported by the notched lugs, a pawl pivot passing through the eye of the pawl and having its

bearings in the back of the case and in the disk, there being a cross bar at the outer end of the pawl pivot, the ring H having a wedge-shaped slot for the reception of the cross bar of the pivot, whereby the pawl is thrown out of contact with the ratchet wheel or into contact with the same by the slight turning movement of the ring upon the hub of the case, substantially as set forth.

3. The ratchet wheel A and its pawl F, in combination with the case C having within it a disk D, a pawl pivot having its bearing in the back of the case and in the disk that is within the case, such pawl pivot having a cross bar at the outer end thereof, and the ring H having a wedge-shaped slot for the reception of the cross bar of the pivot pin, such ring being adapted to receive a partial turning movement to act upon the cross bar of the pivot pin and throw the pawl into or out of contact with the ratchet wheel, and a friction spring applied to the exterior of the ratchet case, substantially as set forth.

4. The ratchet wheel A and its pawl F, in combination with the case C having within it a disk D, a pawl pivot having its bearing in the back of the case and in the disk that is within the case, such pawl pivot having a cross bar at the outer end thereof, and the ring H having a wedge-shaped slot for the reception of the cross bar of the pivot pin, such ring being adapted to receive a partial turning movement to act upon the cross bar of the pivot pin and throw the pawl into or out of contact with the ratchet wheel, a friction spring applied to the exterior of the ratchet case, and lugs upon the exterior of the case, and a stop for arresting the movement of the case, substantially as set forth.

5. The ratchet wheel A and its pawl F, in combination with the case C having within it a disk D, a pawl pivot having its bearing in the back of the case and in the disk that is within the case, such pawl pivot having a cross bar at the outer end thereof, and the ring H having a wedge-shaped slot for the reception of the cross bar of the pivot pin, such ring being adapted to receive a partial turning movement to act upon the cross bar of the pivot pin and throw the pawl into or out of contact with the ratchet wheel, a treadle lever and segmental rack acting upon teeth around the ring H, and a spring to raise the treadle, substantially as set forth.

Signed by me this 4th day of May 1893.

JOS. A. WILKIN.

Witnesses:

GEO. T. PINCKNEY,
A. M. OLIVER.